

# Force Measurements in a Small Space



**Dynamometers**

**TIEDEMANN**

# Ring Dynamometers

## Analogue and Digital Force Measurements

Tiedemann dynamometers, manufactured for more than 60 years, offers high precision instruments for mechanical force measurements for tensile and compressive forces. The measurement range of the ring dynamometers goes from 50 N to 200 kN.

### Applications

The Tiedemann dynamometers are always used where measurements may allow only minimal length changes. They are applied in the measurement of cable tension on overhead wires, as an extension would lead to an increase of slack span. Other applications include high-precision measurements in mechanical engineering and vehicle manufacturing e.g. in test stands for brakes, in machinery and transport equipment, as well as in measurements where only little room for the measuring instrument is available. Their handling is very easy.

The digital version finds further applications in laboratories of R&D, quality and manufacturing control. They are small and easy to use as well. They do not need any amplifier or mains. You can read the forces directly on the screen or via USB cable on your notebook.



*Universal Analogue Dynamometer with standard scale, max 2 kN*



*Manual application of our Ergonomic-Kit with hooks and pressure buffer*



*Y-Cable Tensioning Device for overhead wiring of high speed trains*

## **Execution of the Dynamometer**

The ring dynamometer consists of a special shaped elastic steel ring attached with two facing drawbar eyes, pressure seats or threads. A load on the ring leads to a slight deformation, which is measured with a precise dial gauge.

## **Analogue Indicator - Measured Value and Maximal Load**

The measured deformation is converted through a calibration table into tensile or compressive forces.

The mechanical, analogue 100-dial indicator shows a change in diameter of the ring of 5 microns per division. The ring will deform less than 2.0 mm. The error on accuracy is less than 1 % for the upper 80 % of the range.

On Tiedemann dynamometers, the indicator can be set in such a way that it displays the maximum force in one measuring run. This is of advantage for fast processes and during experiments where reading of scale is difficult or not possible, as may be the case in determining the drag resistance of gliders, towed trailers and boats or an operation force at a inapproachable place.

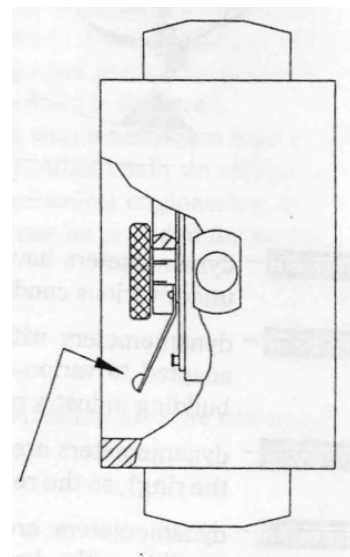

*Lever for maximum load*

## Digital Indicator

The digital indicator has maximal three digits (1  $\mu\text{m}$ ) and will be programmed by Tiedemann during calibration to show the forces direct in N or kN. The smallest measurable force is 0.1 N or 1 N. The max ranges for the digital dynamometer starts from 200 N to 100 kN.



Tensile forces will be marked with a “+“, compression force with the “-“. In case of our Universal-Dynamometer with drawbar eyes and pressure seats the calibration curve for tensile and compressive force has to be chosen.

Further you can set the digits always to “0” by pressing the “Tara” button, but please do not forget the max load for the ring.

Besides the direct reading of the forces on the display the major advantage is the direct connection to a computer to run measurement programs and save the force results. In this case the battery box for the

battery (4000 hours) will be exchanged against a cable connection with USB or RS232. You do not need any further instruments or an external power supply. The indicator itself will be supplied by the power of the notebook.

Tiedemann provides the indicator driver and a basic capture program to transfer the measurement data to WIN-Excel. Alternative any other measurement program can be used.

In cases a wireless connection is of interest or if an application requires more than one dynamometer, you can connect them via a HUB. These technologies are provided by different external partners.



## Choice of Measuring Range

The ring dynamometers are available with various methods in execution. Depending on the design the measurement range lasts from 50 N up to 200 kN.

The universal dynamometers are combination instruments for tensile or compressive forces. Drawbar eyes carry the tensile force whereas pressure seats take the compressive force. Alternative both forces can be connected via screw bolts. Other pure tensile and compression dynamometers are available as well.

The dynamometers are designed for specific ranges that may not be exceeded, not even temporarily by shock. Thus, if the measured force is not exactly known or you are not sure that the force is free of shocks, then the next strongest ring has to be chosen. For continuous (1 hour or longer) or permanent changing loads, only 80 % of the maximum of measuring range may be used.



## Special Designs and Protectors



*Protective jacket*

Because of the diversity of measuring challenges that have to be solved, Tiedemann welcomes your input along the way.

We also offer a splash protective rubber cover on some of our instruments, rotating drawbar eyes or dynamometers with modified seats for compressive forces.

## Calibration

The calibration of our analogue and digital dynamometers with a maximum load up to 100 kN is done with force measuring equipment at Tiedemann. The accuracy of our calibration devices are certified periodically by the measurement office of material testing. They are classified into the grade of quality 0.5 (highest possible accuracy) according to DIN 51220.

Instruments with a higher load are calibrated by the measurement office for material testing for the engineering industry at Stuttgart University. Therefore, it is traceable in all cases to the official comparison standard according to ISO 9000ff.

The determination of the calibration values (10 steady steps from zero to the maximum load) occurs according to the internal testing method following DIN 51301 (increasing and decreasing load and for indication for maximum load). The values are determined separately for each device and slightly corrected according to a compensation curve of minimal quadratic divergence (polynomial of degree 3). By this, incorrect values or irregularities in the dial indicator can be recognized before delivery.

The calibration curve through the 10 given values is almost straight for tensile forces, but slightly curved for compressive force.

For analogue dynamometers a calibration table or a drawn scale for direct readable values is provided, for digital indicators the calibration is saved in the indicator. The indicator shows the values directly in N or kN.

Calibration Table for Ring Dynamometer <b>6C81</b>		
load kN	tension	compression
0	0	0
1	19.9	23.2
2	39.8	46.5
3	59.6	70.1
4	79.4	93.8
5	99.1	117.6
6	118.7	141.7
7	138.2	165.9
8	157.7	190.3
9	177.1	214.9
10	196.4	239.7

Follow the instructions for use

## Analogous Dynamometer with Drawn Scale

Analogous dynamometers with a drawn scale are first calibrated according to the same method.

Then a drawn scale with interpolated force values will replace the standard scale for one arbitrary rotation of the dial gauge. The measurement range then becomes smaller e.g. 0-60 N or 60-120 N for ZS02,



## Important Instructions

The calibrated dynamometers must not be modified after delivery. If the drawbar eyes for tensile forces or the seats for compressive forces are turned or removed, the rigidity of the whole device will be changed. The calibration table and the maximum load are no longer valid.

Tensile forces must always be fed in with a bolt intended for the size of the device (dimension d). Thinner bolts will lead to deformation or breakage of the drawbar eye. As an alternative we offer special high strength steel shackles.

Compressive forces are preferably fed in by steel balls:

Diameter of balls	up to 10 kN	about 7 mm
	up to 100 kN	about 15 mm
	up to 200 kN	about 25 mm

The ring of the dynamometer must not be engraved or it will be in danger of breakage.

## Repair and Calibration Services

According to DIN 51301, the testing certificate is valid for only 24 months. Therefore, it is recommended to recalibrate the device after this period.

Tiedemann will provide this calibration service. The performance of the dynamometer is examined before calibration. In case the dynamometer is from Tiedemann, damaged parts are replaced by new ones automatically. After recalibration, our company will deliver a practically new instrument. If required Tiedemann would provide a test certificate showing the repair and calibration for dynamometers with a maximum load of 100 kN (necessary for quality control according ISO 9000ff.) Additionally and for dynamometers for higher forces, an official test certificate from the measurement office of material testing can be provided.

## **Technical Data**

The following pages show all configurations and the technical data for:

- Analogue Universal Dynamometers for tensile or compressive force with calibration table.
- Analogue Universal Dynamometers with screw joint for tension and compression with calibration table
- Analogue Compressive Force Dynamometers with calibration table or drawn scale for direct read
- Analogue Tensile Force Dynamometers with calibration table or drawn scale for direct read

The digital Ring-Dynamometers have the same shapes as the analogue types. We offer the same four different types. However the range is limited to 200 N to 100 kN. The name of the Dynamometer is marked with the symbol "dig." behind the name like U-5 dig or Z-1 dig.

The two optional cables for PC connection have to be ordered separately. They come with the Tiedemann-Capture-Program incl. indicator driver.

## Universal Dynamometers Tensile & Compressive Forces

With these universal dynamometers, either tensile or compressive forces (according to the direction of mounting) can be measured without any alteration.

Each instrument is calibrated individually. The calibration values (10 determined values for both tension and compression) are given in a calibration table.

The digital Dynamometers are marked with a "dig." behind the type name like U10dig.

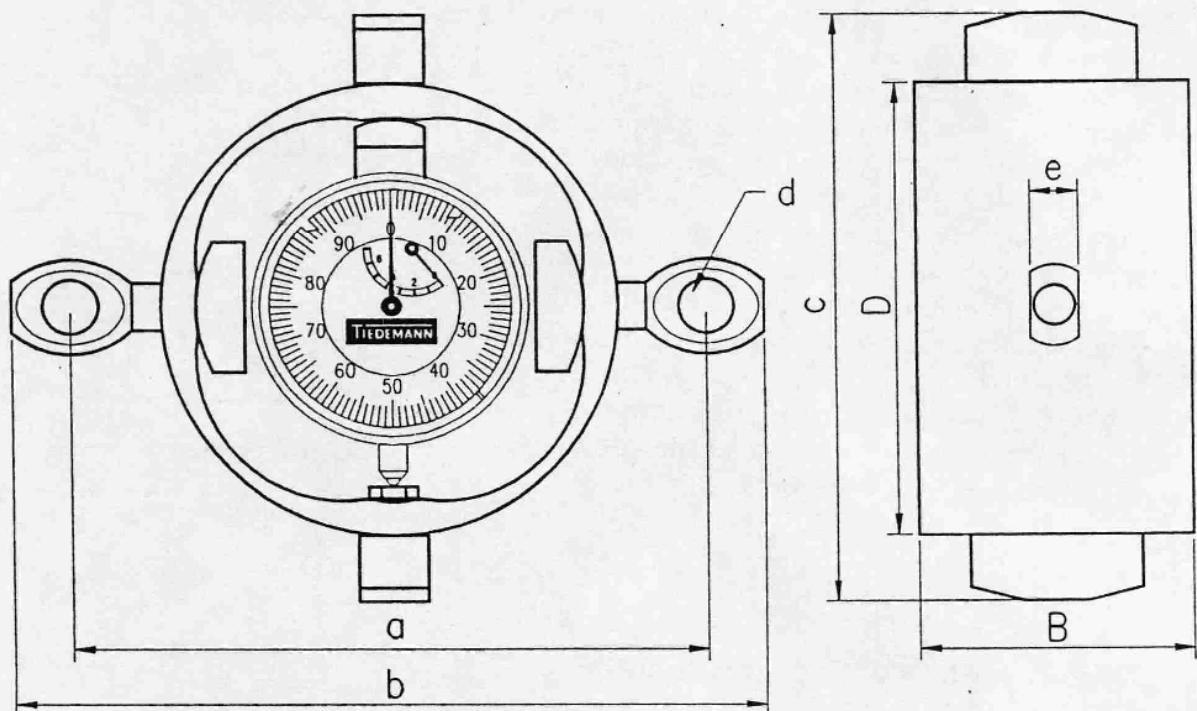

with calibration table:

Type		U02	U05	U-1	U-2	U-5	U10	U20	U50
Measuring range	N (kN)	200	500	1kN	2	5	10	20	50
Dimensions according to sketch (mm)	B	27	27	27	35	35	40	55	65
	D	60	60	60	60	66	66	80	104
	a	82	82	82	82	88	92	112	154
	b	96	96	96	96	102	110	131	183
	c	79	79	79	80	86	86	104	128
	d	6	6	6	6	6	8	10	15
	e	7	7	7	7	7	8	11	15
Indication	tension (g. m.)	300	300	300	300	250	200	200	230
	compr. (g. m.)	350	350	350	350	300	250	250	280
Accuracy	±N	0,6	1	2	4	10	25	50	120
Weight	kg	0,14	0,15	0,18	0,25	0,3	0,4	0,8	1,8



## Universal-Dynamometers with Screw Joints for Tensile / Compressive Force

With this model the forces are fed via the thread bolts for tensile and compressive forces at the same bolts. Thus, this type is ideal for alternating loads.

When the analogue device is unloaded, the dial indicates 300 graduation marks. If the forces are tensile, the indication will rise; if the forces are compressive, the value will decrease. Therefore, the indication for maximum load works with tensile forces only.

The digital indicator starts with 0.0 N or 0.000 kN. Tension will be indicated with a "+" symbol, compression has a "-". In case of digital product order please mark the Dynamometer name with a „dig” behind the standard type name, like ZD-2dig.

Calibration Table for Ring Dynamometer <b>7B37</b>		
load kN	tension	compression
0	300.0	300.0
2	319.9	280.4
4	339.8	260.7
6	359.6	240.9
8	379.5	221.0
10	399.2	201.1
12	419.0	181.0
14	438.6	161.0
16	458.2	140.9

Follow the instructions for use

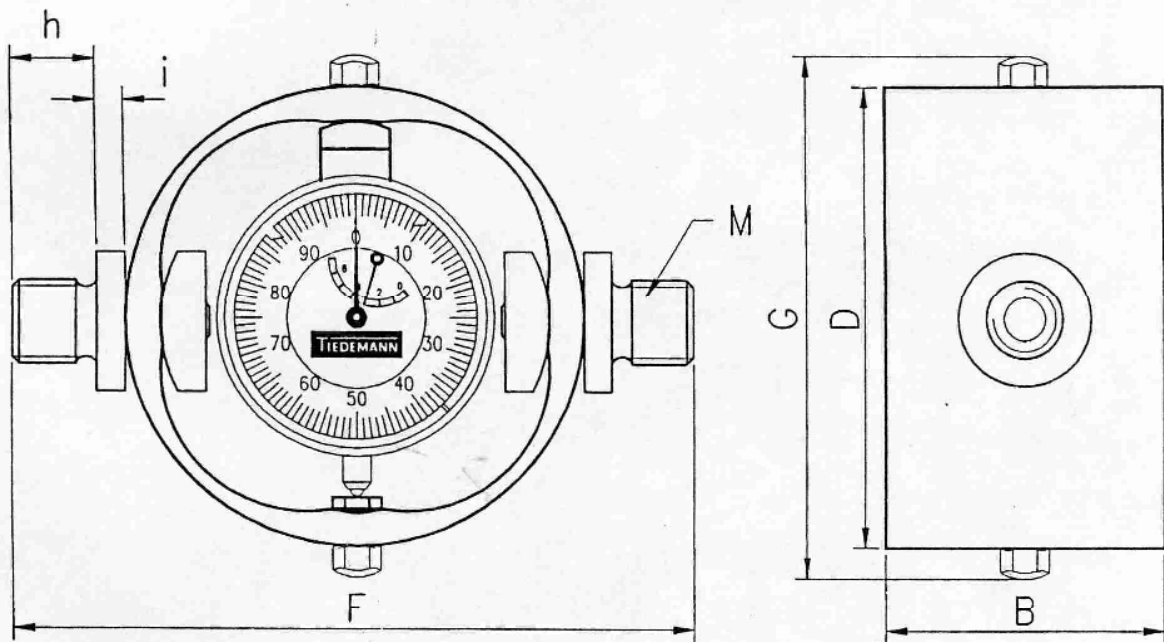

Type		ZD02	ZD05	ZD-1	ZD-2	ZD-5	ZD10	ZD20
Measuring range	N (kN)	±160	±400	±800	±1,6kN	±4	±8	±16
Dimensions according to scetch (mm)	B	27	27	27	35	35	40	55
	D	60	60	60	60	66	66	80
	F	80	80	80	92	100	100	114
	G	72	72	72	72	78	78	106
	h	10	10	10	12	12	12	12
	i	0	0	0	4	5	5	5
Thread	M	10	10	10	12	12	12	12
Indication	(g.m.)	520	520	520	520	440	360	360
Indication	±N	0,6	1	2	4	10	25	50
Weight	kg	0,14	0,15	0,18	0,25	0,3	0,4	0,8

## Compression Force Dynamometers

The calibration and application is only for compression. The analogue instrument is provided with a calibration table or a drawn scale for direct read of forces.

The digital Compression Force Dynamometers will be marked with “dig” behind the type name , like D20dig.

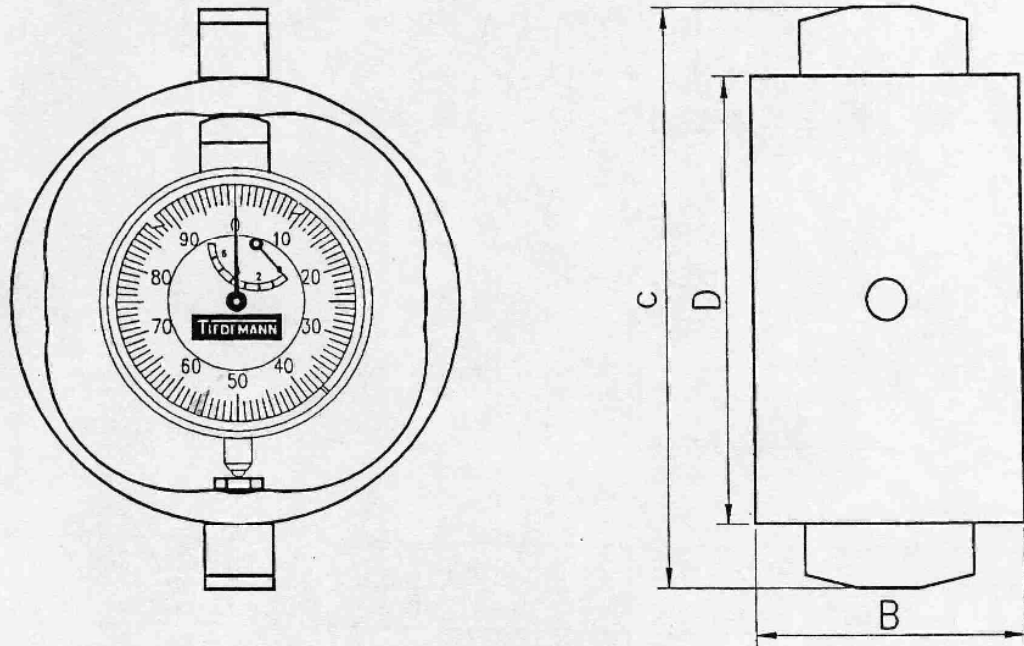

with calibration table:

Type	DT02	DT05	DT-1	DT-2	DT-5	DT10	DT20	DT50	DT100	DT200
Range N (kN)	200	500	1kN	2	5	10	20	50	100	200
Dimensions B	27	27	27	35	35	40	55	65	75	98
according to D	60	60	60	60	66	66	80	104	113	135
scetch (mm) c	79	79	79	80	86	86	104	128	143	175
Indication (steps)	350	350	350	350	300	250	250	280	200	200
Accuracy $\pm N$	0,6	1	2	4	10	25	50	120	250	500
Weight kg	0,12	0,14	0,15	0,21	0,27	0,34	0,7	1,5	2,2	4,8

with drawn scale:

Type	DS02	DS05	DS-1	DS-2	DS-5	DS10	DS20	DS50	DS100	DS200
Range N (kN)	50	130	260	540	1,5kN	3,8	8	18	45	90
Maximum load up to N (kN)	200	500	1kN	2	5	10	20	50	100	200
Dimensions B	27	27	27	35	35	40	55	65	75	98
according to D	60	60	60	60	66	66	80	104	113	135
sketch (mm) c	79	79	79	80	86	86	104	128	143	175
Accuracy $\pm N$	0,6	1	2	4	10	25	50	120	250	500
Weight kg	0,12	0,14	0,15	0,21	0,27	0,34	0,7	1,5	2,2	4,8

## Tensile Force Dynamometers

The calibration and application is only for tensile force. The analogue instrument is provided with a calibration table or a drawn scale for direct read of forces.

The digital Tensile Force Dynamometers will be marked with "dig" behind the type name, like Z-1dig.

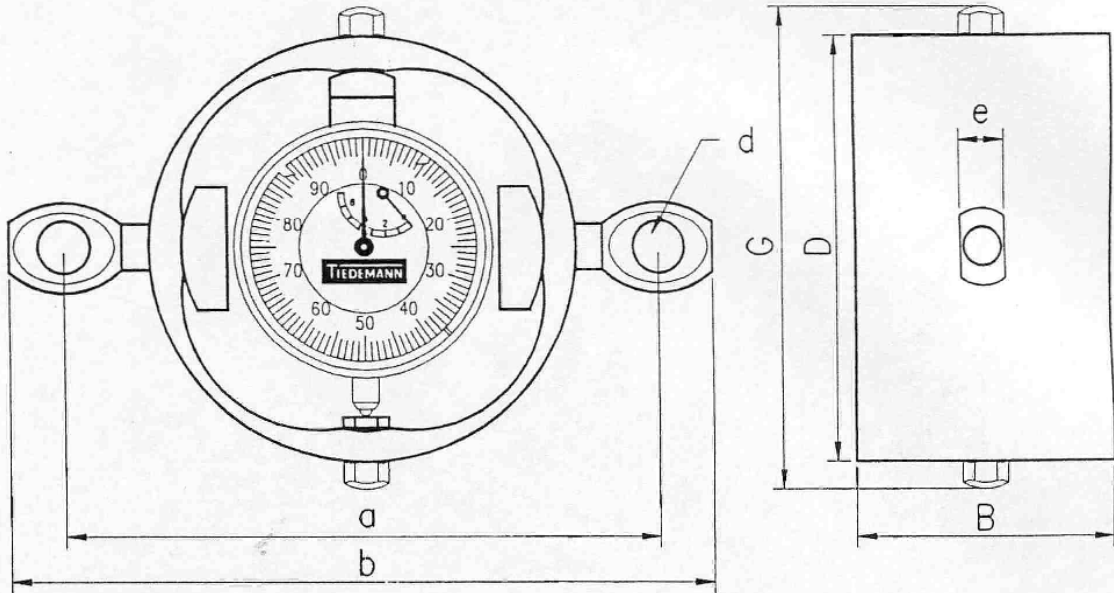

with calibration table:

Type		ZT02	ZT05	ZT-1	ZT-2	ZT-5	ZT10	ZT20	ZT50	ZT100	ZT200
Range	N (kN)	200	500	1kN	2	5	10	20	50	100	200
Dimensions according to scetch (mm)	B	27	27	27	35	35	40	55	65	75	98
	D	60	60	60	60	66	66	80	104	113	135
	G	72	72	72	72	78	78	106	130	139	161
	a	82	82	82	82	88	92	112	154	167	210
	b	96	96	96	96	102	110	131	183	207	270
	d	6	6	6	6	6	8	10	15	20	30
	e	7	7	7	7	7	8	11	15	21	28
Indication	(steps)	300	300	300	300	250	200	200	230	200	240
Accuracy	±N	0,6	1	2	4	10	25	50	120	250	500
Weight	kg	0,13	0,14	0,15	0,22	0,27	0,35	0,7	1,7	2,7	5,4

with drawn scale:

Type		ZS02	ZS05	ZS-1	ZS-2	ZS-5	ZS10	ZS20	ZS50	ZS100	ZS200
Range	N (kN)	60	150	300	600	1,8kN	4,7	10	23	48	80
Maximum load up to	N (kN)	200	500	1kN	2	5	10	20	50	100	200
Dimensions according to scetch (mm)	B	27	27	27	35	35	40	55	65	75	98
	D	60	60	60	60	66	66	80	104	113	135
	G	72	72	72	72	78	78	106	130	139	161
	a	82	82	82	82	88	92	112	154	167	210
	b	96	96	96	96	102	110	131	183	207	270
	d	6	6	6	6	6	8	10	15	20	30
	e	7	7	7	7	7	8	11	15	21	28
Accuracy	±N	0,6	1	2	4	10	25	50	120	250	500
Weight	kg	0,13	0,14	0,15	0,22	0,27	0,35	0,7	1,7	2,7	5,4



Tiedemann Instruments GmbH & Co. KG Zur Maximilianshöhe 6 82467 Garmisch-Partenkirchen Germany  
Phone: +49-8821-3068 Fax: +49-8821-3922 Cell Phone: +49-160-97 8443 96 info@Tiedemann-Instruments.de  
www.Tiedemann-Instruments.de